

Using IPU for Pump Sleep Application

TN-012

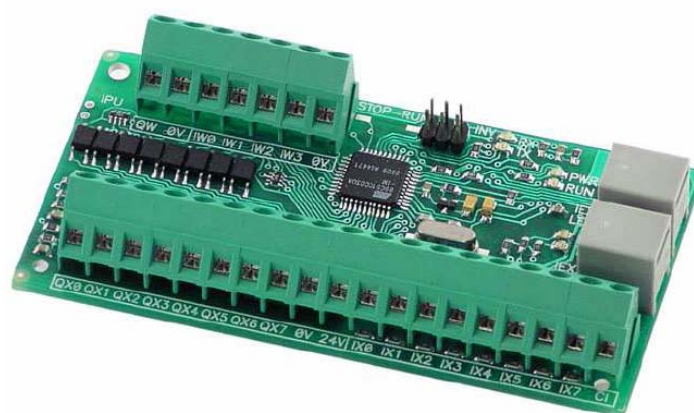

cybroTech

© 2008 Cybrotech Ltd

Cybrotech, Ltd.
14 Brinell Way
Harfreys Industrial Estate, Great Yarmouth
Norfolk, Nr31 0LU – UK
tel: +44 (0)1493 650 222
www.cybrotech.co.uk
info@cybrotech.co.uk

&

Sirteg GbR
Max-Planck-Strasse 5
58638 Iserlohn - Deutschland
tel: +49 (0)2371 7977 77
fax: +49 (0)2371 7977 99
www.sirteg.de
info@sirteg.de

Copyright © 2008 Cybrotech Ltd.
Subject to change without notice
PBL-TN018-EN-2008-12

1. General Description

The IPU-PSM is an option board for the Hitachi L300P and SJ300 series of AC Variable Frequency Inverters which adds Pump Sleep Mode functionality to the standard built-in PID function. The IPU-PSM board can be installed in either of the two available option slots in the inverter. The discussions in this manual assume that the inverter application is a fluid pumping system, in which a fixed pressure is to be maintained in the face of varying flow demands. However, there is no reason the IPU-PSM cannot be adapted for other application types.

Standard PID control may, depending on system demand, allow the pump to operate at undesirably low speeds for prolonged periods of time. This can cause mechanical issues with certain pump types, and in general is very wasteful of energy, since most pumps do not generate significant flow or head at low speeds. The IPU-PSM allows for the specification of a lower limit on inverter output frequency. Should the PID function call for a frequency below that limit for a user defined period of time, the inverter will go to “sleep”, meaning the inverter output will shut off and the pump stops. The IPU-PSM monitors the system pressure feedback via the inverter’s PID Deviation parameter. If system pressure drops below a defined level for a specified period of time, the inverter will “wake” and resume normal PID pressure regulation. In addition to this automatic operation, two digital inputs are available on the IPU-PSM: to force the inverter to wake, and to disable the sleep function.

Before using this product, please read this manual and the relevant inverter manual, and be sure to follow all safety precautions. After unpacking the IPU-PSM board, carefully inspect it for any defects or damage, and be sure all parts are present.

Carton Contents

- (1) IPU-PSM Board
- (2) Screws to secure board to inverter case (M3 x 8mm)

WARRANTY

The warranty period under normal installation and handling conditions shall be thirty-six (36) months from the date of purchase. The warranty shall cover repair or replacement, at Hitachi’s sole discretion, of the IPU-PSM Option board.

Service in the following cases, even within the warranty period, shall be to the customers account:

1. Malfunction or damage caused by misuse, modification or unauthorized repair.
2. Malfunction or damage caused by mishandling, dropping, etc., after delivery.
3. Malfunction or damage caused by fire, earthquake, flood, lightning, abnormal input voltage, contamination, or other natural disasters.

If service is required for the product at your worksite, all expenses associated with field repair are the purchaser’s responsibility. This warranty only covers service at Hitachi designated service facilities.

If making a warranty claims in reference to the above, please contact the distributor from whom you purchased the IPU-PSM, and provide the model number, purchase date, installation date, and description of damage or missing components.

SAFETY PRECAUTIONS



HIGH VOLTAGE: This symbol indicates high voltage. It calls your attention to items or operations that could be dangerous to you and other persons operating this equipment. Read the message and follow the instructions carefully.



WARNING: Indicates a potentially hazardous situation that, if not avoided, can result in serious injury or death.



CAUTION: Indicates a potentially hazardous situation that, if not avoided, can result in minor to moderate injury, or serious damage to the product. The situation described in the CAUTION may, if not avoided, lead to serious results. Important safety measures are described in CAUTION (as well as WARNING), so be sure to observe them.



HIGH VOLTAGE: Motor control equipment and electronic controllers are connected to hazardous line voltages. When servicing drives and electronic controllers, there may be exposed components with housings or protrusions at or above line potential. Extreme care should be taken to protect against shock. Stand on an insulating pad and make it a habit to use only one hand when checking components. Always work with another person in case an emergency occurs. Disconnect power before checking controllers or performing maintenance. Be sure equipment is properly grounded. Wear safety glasses whenever working on electronic controllers or rotating machinery.



WARNING: This equipment should be installed, adjusted, and serviced by qualified electrical maintenance personnel familiar with the construction and operation of the equipment and the hazards involved. Failure to observe this precaution could result in bodily injury.



WARNING: HAZARD OF ELECTRICAL SHOCK. DISCONNECT INCOMING POWER BEFORE WORKING ON THIS CONTROL.



WARNING: Wait at least five (5) minutes after turning OFF the input power supply before performing maintenance or an inspection. Otherwise, there is the danger of electric shock.



WARNING: Do not install or remove the IPU-PSM Modbus option board while the inverter is energized. Otherwise there is the danger of electric shock and/or injury due to unexpected inverter operation.



WARNING: Never modify the unit. Otherwise, there is a danger of electric shock and/or injury.



CAUTION: Be sure to secure the IPU-PSM option board with the supplied mounting screws. Make sure all connections are made securely; otherwise there is danger of a loose connection and unpredictable operation.



CAUTION: Alarm connection may contain hazardous live voltage even when inverter is disconnected. When removing the front cover for maintenance or inspection, confirm that incoming power for alarm connection is completely disconnected.



CAUTION: Be sure not to touch the surface or terminals of the IPU-PSM Modbus option board while the inverter is energized; otherwise there is the danger of electric shock.

INVERTER COMPATIBILITY

ALL inverters in the model number series **L300P-xxxXFU₂** are compatible with the IPU-PSM.

ALL SJ300 and L300P inverters manufactured in 2004 or later (Date Code 0401 and higher) are compatible.

Older Inverters

Only if this board is to be installed in older inverters manufactured **before** 2004, it will be necessary to check the compatibility as follows.

The inverter firmware revision number is embedded within the inverter Manufacturing Number, which can be found on the product nameplate. The IPU-PSM Modbus Interface option board is compatible only with SJ300 and L300P series inverters with Revision Numbers HIGHER than those shown below.

XX**8KT** XXXXX XXXXX – for SJ300-xxxXFU 0.4 kW (0.5 hp) to 55 kW (75 hp), or L300P-xxxXFU or L300P-xxxXB₂RM 1.5 kW (2 hp) to 75 kW (100 hp)

XX**EMT** XXXXX XXXXX – for SJ300-xxxXFU 75kW (100 hp) to 150 kW (200 hp), or L300P-xxxXFU or L300P-xxxXB₂RM 90 kW (125 hp) to 132 kW (175 hp)

2. Installation and Wiring

Orientation to Product Features

Figure 2-1 below shows the physical layout of the IPU-PSM option board.

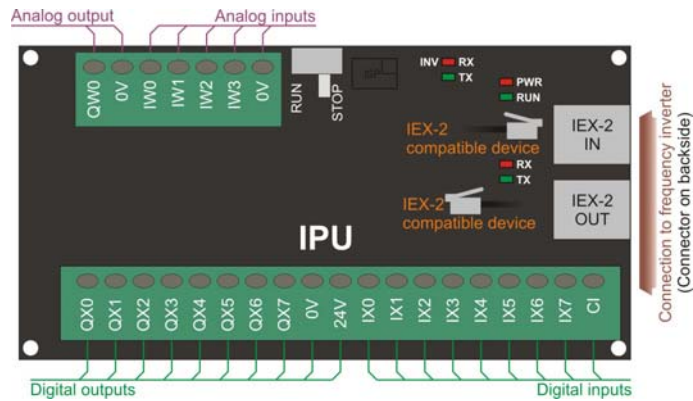

Figure 2-1: IPU-PSM

Installing the Option Board

Power down the inverter and wait at least five minutes before moving to the next step. Open and remove the lower terminal cover. Confirm that the red CHARGE LED is extinguished and that the DC bus is fully discharged before proceeding further, otherwise there is the danger of electric shock. Then remove keypad from the inverter. You can now remove the upper front cover to expose the two option ports inside.

Figure 2-2 on the next page shows how to install the option board to option port 1 or 2 of the inverter. There are four holes on the corners of the option board. Align the board with the port connector in the proper orientation (to the left, when facing the inverter as show). Then align the top two holes with the two screw holes, and the bottom two holes with the two guide posts. Insert the board fully into the connector. Secure the board with the two M3 screws supplied.

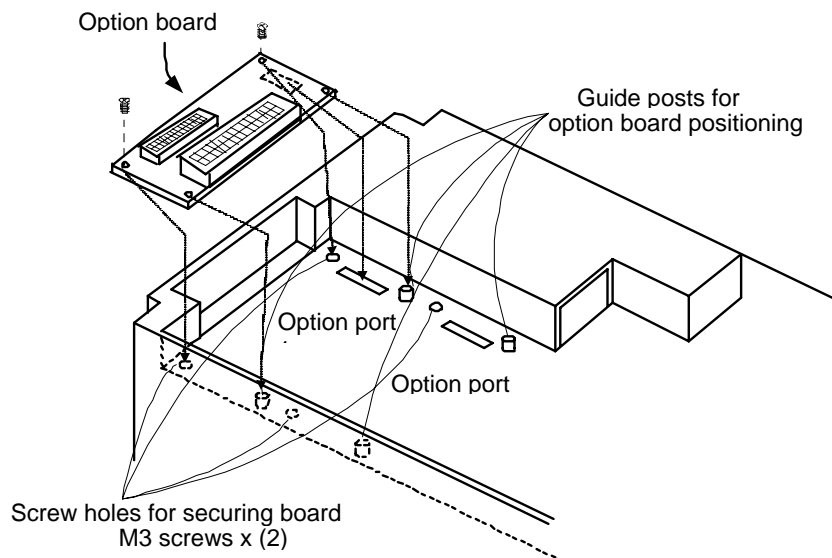

Figure 2-2: Installation of IPU-PSM

Wiring

Digital Inputs

Only digital inputs IX0 and IX1 are functional input points on the IPU-PSM. The common terminal for these inputs is CI. The terminals can be sinking or sourcing, and a source of 24 Vdc power is required to energize them, as shown in Figure 2-3. The inverter's internal 24 Vdc supply or an external DC power supply can be used for this purpose, wired in series with the external switching devices as shown. All other inputs on the IPU-PSM have no function. Do NOT wire to the inverter FW or RV inputs. RUN/STOP is controlled by IX0 on the IPU. All other inverter I/O can be used and will function normally.

The functions of the two inputs are as follows:

Input	Function	Logic	Description
IX0	RUN Request	Normally Open	This is the RUN signal when using the IPU-PSM. (the FW/RV RUN inputs on the inverter input terminals ARE NOT to be used when the IPU-PSM is installed). This input must be ON to operate the inverter. A transition from OFF to ON when in sleep mode, the inverter will exit sleep mode and begin running. Sleep mode will be entered again when configured conditions are again met.
IX1	Alarm Start	Normally Open	Sleep Mode is disabled when ON. A transition from OFF to ON when in sleep mode will restart the inverter immediately. Sleep mode will NOT be entered, regardless of conditions, while this input remains ON. PID control remains active.

Digital Input Specifications: 24 Vdc, Opto-isolated, Bipolar Sink/Source, 7 mA nominal

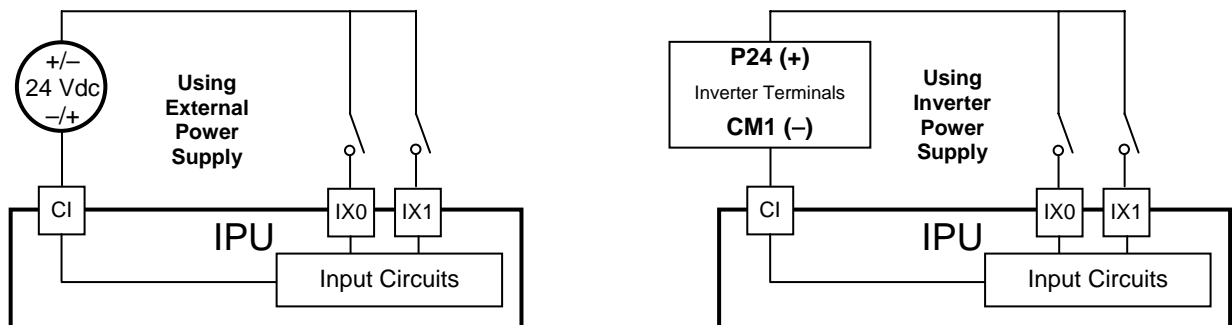

Figure 2-3

Digital Outputs

Only digital outputs QX0 and QX1 are defined for the IPU-PSM. All other outputs have no function. Typical wiring is shown in Figure 2-4.

The functions of the two digital outputs are as follows:

Output	Function	Logic	Description
QX0	RUN	Normally Open	This output is ON when the drive is in RUN mode. It mirrors the [RUN] output on the inverter and the RUN LED on its keypad.
QX1	SLEEP	Normally Open	If sleep mode is enabled (IX1 is OFF), this output will be ON when the inverter is sleeping, and OFF when it is awake. If sleep mode is disabled (IX1 is ON), this output will remain OFF.

Digital Output Specifications: N-Channel V-FET (current source, load to ground), Opto-isolated, 1.0A/30Vdc

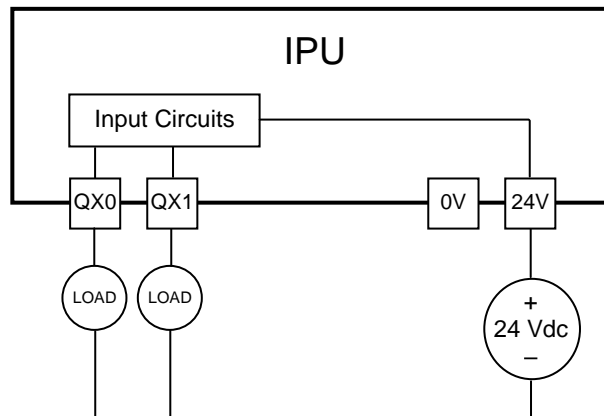

Figure 2-4

Analog Inputs and Outputs

The analog input and outputs are NOT used in the IPU-PSM. They have no function.

3. Configuration

Configuration of the IPU-PSM

Ensure that the IPU-PSM is properly installed as described in Chapter 2. Be sure the RUN/STOP switch on the IPU-PSM is in the RUN position. Set up the standard inverter PID parameters as described in the pertinent inverter instruction manual as required, to meet the requirements of the application. Configuration of the IPU-PSM is accomplished through inverter parameters. The IPU-PSM redefines four inverter parameters for use in the control of the sleep mode functions. For this reason, the 2nd motor functions of the inverter cannot be used when an IPU-PSM is installed. Please review the details of these functions in the inverter manual.

Configuring Inverter Parameters that Control Sleep Mode

Using either the inverter keypad, or the ProDrive Configuration Software, the five parameters in the table below must be set as described in order to establish the proper pump sleep mode operation.

Function Code	Name	Description of Standard Function Function with IPU-PSM	Run Mode Edit Lo Hi	Defaults			Setting for Pump Sleep Mode with IPU-PSM
				-FE (EU)	-FU (US)	-FR (JPN)	
A002	RUN command source setting	Five option codes – determines inverter RUN command source	x x	01	01	02	02
A062	Frequency Lower Limit	Lower limit, in Hz, for inverter output frequency Activation level for Sleep Mode	x ✓	0.00	0.00	0.00	Desired lowest frequency of operation for your pump
F202	Acceleration Time, 2 nd Motor	2 nd Motor Acceleration Time Time, in seconds, that the commanded frequency has to be below A062 value before Sleep Mode is initiated	✓✓	30.0	60.0	30.0	Set a value that will provide appropriate action. Be careful not to set a value too low, as the inverter will enter/exit Sleep Mode too often
F203	Deceleration Time, 2 nd Motor	2 nd Motor Deceleration Time Time, in seconds, after PID deviation exceeds the threshold (C044)	✓✓	30.0	60.0	30.0	Set a value that will provide appropriate action. Be careful not to set a value too low, as the inverter will enter/exit Sleep Mode too often
C044	PID Deviation Level Setting	PID Deviation Level for [OD] Output Percent deviation from setpoint to trigger the inverter to wake up from Sleep Mode	x ✓	3.0	3.0	3.0	Set the percent below the desired target pressure at which you wish the inverter to “wake” and restart the pump

5. Troubleshooting

In general, the first step to troubleshooting should be inspection of the IPU-PSM board for any visible signs of damage. Make sure the RUN/STOP switch is in the RUN position. Also observe the six LEDs on the IPU-PSM. The PWR and RUN LEDs should be illuminated, and the two pairs of RX/TX LEDs should be flashing rapidly.

In addition, the inverter operator/keypad will provide diagnostic information for certain types of errors. Error codes for the option boards will have the format of:

E6X.X for a board installed in option slot 1, or **E7X.X** for a board installed in option slot 2. The number to the right of the decimal point indicates the drive status at the time of trip, as follows:

EXX.0	At reset	EXX.1	At stop	EXX.2	During deceleration
EXX.3	At constant speed	EXX.4	During acceleration	EXX.5	f0 Stop
EXX.6	At starting	EXX.7	During DC injection braking	EXX.8	During overload restriction

The digit immediately to the left of the decimal point has the following meaning:

Code	Trip Name	Cause	Check	Remedy
EX0.X	IPU-PSM Error	Board Internal Fault	Board is properly seated in connector	Press STOP/RESET on inverter keypad; cycle power to inverter; replace IPU-PSM
EX9.X	Internal Communication Error (between IPU and inverter)	Option board ajar or loose	Board is properly seated in connector	Remove and reseal board
	Inverter Mismatch (blinking display as shown)	Inverter firmware version not compatible with IPU-PSM option board	Inverter Manufacturing Number for version (see Page 7)	Replace Inverter with later version

Appendix: Optional Keypad OP2i



The optional OP2i keypad/display affords a single simplified interface for monitoring and control of the inverter/IPU-PSM system. It has a 2-line LCD display and keys that control its operation. The OP2i connects to the IPU-PSM “IEX2-OUT” connector by means of a standard RJ11 4-wire (telephone) cable. See [Figure 2-1](#).

The OP2i provides two pages of useful information that can be accessed by using the Up ▲ key.

Control Page

SP: This represents the internal PID setpoint of the inverter.

PV: Shows the actual process variable feedback value (same as inverter display D004).

RQ: Status of user RUN Request (IX0)

OF: start is not permitted by user

ON: inverter is free to start immediately, or after wake conditions are reached if in sleep mode.

SQ: Status of sleep mode (IX1) – OF: sleep mode is disabled; ON: sleep mode is enabled.

Note: Both RQ and SQ show the condition of the respective input signals, UNLESS you change the value via the keypad. In this case, the input is overridden, until the input signal transitions. An input signal transition will then override the last key press.

Monitoring Page

FM: This shows the current frequency output of the inverter.

Lo: This is the set value A062

SM: Status of sleep mode

OF: Sleep mode is off

AS: Awake – sleep mode is enabled and the inverter is running

SL: Sleeping – sleep mode is enabled and inverter is asleep

ST: Status of the current RUN condition of the inverter

ST: The inverter is in STOP mode

RN: The inverter is in RUN mode

Keypad Control

Three of the keys on the OP2i are configured to operate with the IPU-PSM, as follows:

Key UP ▲ Navigates through the control and monitoring pages

Key Check ✓ Toggles the RUN Request. Every change from OFF to ON will immediately start the inverter.

Key F Toggles the state of the sleep function. A change from ON to OFF while inverter is in sleep mode will immediately restart the inverter (Alarm-Start).

Combined Terminal/Keypad Control

Since all inputs (keypad or terminal) are triggered on a transition, both input types can be used together. In other words, the inverter can be controlled by the OP2i, yet still have an alarm relay connected to IX1 to wake the inverter if a critical limit is reached, for example.